

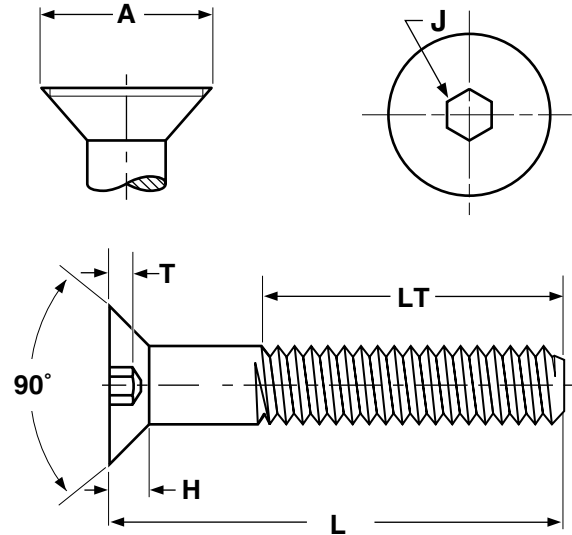

Metric Products

Metric Flat Head Socket Cap Screws



Nominal Size	Thread Pitch	B		A		H		J	T	W	D	
		Body Diameter		Head Diameter		Head Height		Hex Socket Size	Key Engagement	Wall Thickness	Drill Allowance	
		Max	Min	Theoretical Sharp	Absolute Min.	Ref	Flush Tolerance	Nom	Min	Min	Max	
M3	0.5	3.00	2.86	6.72	5.35	1.86	0.30	2.0	1.1	0.25	0.3	
M4	0.7	4.00	3.82	8.96	7.80	2.48	0.30	2.5	1.5	0.45	0.4	
M5	0.8	5.00	4.82	11.20	9.75	3.10	0.35	3.0	1.9	0.66	0.5	
M6	1	6.00	5.82	13.44	11.70	3.72	0.35	4.0	2.2	0.70	0.6	
M8	1.25	8.00	7.78	17.92	15.60	4.96	0.40	5.0	3.0	1.16	0.8	
M10	1.5	10.00	9.78	22.40	19.50	6.20	0.50	6.0	3.6	1.62	0.9	
Tolerance on Length		Up to 16mm, incl.: ±0.3				Over 16mm to 60mm, incl.: ±0.5			Over 60mm to 150mm, incl.: ±0.8			

ANSI/ASME B18.3.5M

The value-added source for quality bolts, screws, nuts, washers and other industrial fasteners.

3211 West 9th Street, Trainer, PA 19061-5242 TOLL FREE: 1-800-662-7459 LOCAL: 610-485-5700 FAX: 610-485-5877

E-MAIL: sales@coburnmyers.com